



For more Hi-Fi manuals and set-up information
please visit www.hifiengine.com

YAMAHA K-1020

*Natural Sound Stereo Cassette Deck
Closed Loop Dual Capstan Mechanism
Pure Sendust Alloy Recording and Playback Heads
High-Quality, Low-Distortion Amplifiers
ORBIt (Optimum Record Bias Tuning) System
HX Professional Dynamic Bias Servo System
Double dbx, Double Dolby B/C NR
Extra Fluorescent Multi Display/Wide-Range Peak Level Meters/4-Digit Linear Real-Time Counter
Master Fader Control, Double-Action High-Speed Fast Wind
Versatile Auto/Memory Features*

Thank you for purchasing the YAMAHA K-1020 Stereo Cassette Deck.

CONTENTS

CAUTIONS	12
FRONT PANEL PARTS AND FUNCTIONS	3
MULTI-FUNCTION DISPLAY	5
LINEAR COUNTER	5
CONNECTION DIAGRAM	6
THE HX PROFESSIONAL (DYNAMIC BIAS SERVO) SYSTEM	7
DOLBY NOISE REDUCTION	7
dbx SYSTEM	8
3-HEAD CONFIGURATION AND AUTO MONITOR SYSTEM	8
BIAS ADJUSTMENT	9
RECORDING	10
SETTING THE RECORDING LEVEL	11
FADE-IN, FADE-OUT RECORDING	11
PLAYBACK	12
TIMER RECORDING AND TIMER PLAYBACK	13
MAINTENANCE	13
CASSETTE TAPES	14
TROUBLESHOOTING	15
BLOCK DIAGRAM	17
SPECIFICATIONS	18

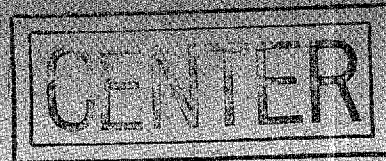

OWNER'S MANUAL



IMPORTANT!

Please record the serial number of your unit in the space below.

Model **K-1020**

Serial No. _____

The serial number is located on the rear of the cabinet.

Retain this Owner's Manual in a safe place for future reference.

WARNING

To prevent fire or shock hazard, do not expose this appliance to rain or moisture.

SAFETY INSTRUCTIONS

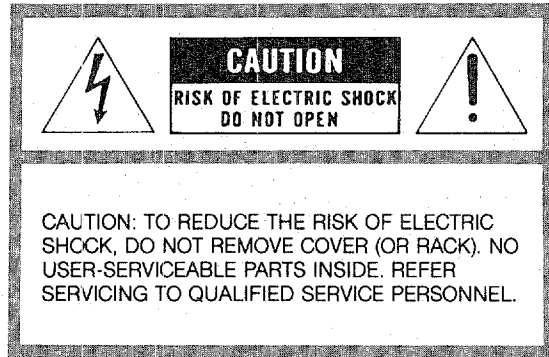

• Explanation of Graphic Symbols



The lightning flash with arrowhead symbol, within an equilateral triangle, is intended to alert you to the presence of uninsulated "dangerous voltage" within the product's enclosure that may be of sufficient magnitude to constitute a risk of electric shock to persons.



The exclamation point within an equilateral triangle is intended to alert you to the presence of important operating and maintenance (servicing) instructions in the literature accompanying the appliance.

- 1** Read Instructions—All the safety and operating instructions should be read before the appliance is operated.
- 2** Retain Instructions—The safety and operating instructions should be retained for future reference.
- 3** Heed Warnings—All warnings on the appliance and in the operating instructions should be adhered to.
- 4** Follow Instructions—All operating and other instructions should be followed.
- 5** Water and Moisture—The appliance should not be used near water—for example, near a bathtub, washbowl, kitchen sink, laundry tub, in a wet basement, or near swimming pool, etc.
- 6** Carts and Stands—The appliance should be used only with a cart or stand that is recommended by the manufacturer.
- 7** Wall or Ceiling Mounting—The appliance should be mounted to a wall or ceiling only as recommended by the manufacturer.
- 8** Ventilation—The appliance should be situated so that its location or position does not interfere with its proper ventilation. For example, the appliance should not be situated on a bed, sofa, rug, or similar surface that may block the ventilation openings; or placed in a built-in installation, such as a bookcase or cabinet that may impede the flow of air through the ventilation openings.
- 9** Heat—The appliance should be situated away from heat sources such as radiators, stoves, or other appliances that produce heat.
- 10** Power Sources—The appliance should be connected to a power supply only of the type described in the operating instructions or as marked on the appliance.
- 11** Power-Cord Protection—Power-supply cords should be routed so that they are not likely to be walked on or pinched by items placed upon or against them, paying particular attention to cords at plugs, convenience receptacles, and the point where they exit from the appliance.
- 12** Cleaning—The appliance should be cleaned only as recommended by the manufacturer.

K-1020

**CAUTION: READ THIS BEFORE
OPERATING YOUR K-1020**

13 Nonuse Period—The power cord of the appliance should be unplugged from the outlet when left unused for a long period of time.

14 Object and Liquid Entry—Care should be taken so that objects do not fall into and liquids not spilled into the inside of the appliance.

15 Damage Requiring Service—The appliance should be serviced by qualified service personnel when:

- A. The power-supply cord or the plug has been damaged; or
- B. Objects have fallen, or liquid has been spilled into the appliance; or
- C. The appliance has been exposed to rain; or
- D. The appliance does not appear to operate normally or exhibits a marked change in performance; or
- E. The appliance has been dropped, or the cabinet damaged.

16 Servicing—The user should not attempt to service the appliance beyond those means described in the operating instructions. All other servicing should be referred to qualified service personnel.

1

The K-1020 is a sophisticated stereo cassette tape deck. To ensure proper operation for the best possible performance, please read this manual carefully.

2

Choose the installation location of your K-1020. Avoid placing it in direct sunlight or close to a source of heat. Also avoid locations subject to vibration and excessive dust, heat, cold or moisture. Keep it away from such sources of hum as transformers or motors.

3

Do not open the cabinet as this might result in damage to the set or electrical shock. If a foreign object should get into the set, contact your dealer.

4

When removing the power plug from the wall outlet, always pull directly on the plug; never yank the cord.

5

Do not use force when using the switches and knobs.

6

If the K-1020 gets wet (from spilled liquids, rain, etc.) immediately pull out the plug; contact your dealer.

7

Do not attempt to clean the K-1020 with chemical solvents as this might damage the finish.
Use a clean, dry cloth.

8

The recording/playback head used in this cassette tape deck is a Pure Sendust alloy head, with inherently high signal-to-noise ratio and excellent recording distortion characteristics, but it can become dirty through the use of old tapes or from dust. This can have a disastrous effect on quality: clean the heads regularly with one of the commonly available cleaning tapes or other cleaning device.

9

The K-1020 is compatible with metal tapes. Use either Normal (LH), CrO₂ (Chrome), or Metal tapes.

10

After putting a cassette back into its case, store in a location away from exposure to direct sunlight, humidity, high temperatures, and magnetic fields (away from television sets, speakers, etc.). High temperatures and humidity will damage the tape itself, while exposure to magnetic fields may cause a loss of recorded material.

11

Be sure to read the "troubleshooting" section for advice on common operating errors before concluding that your K-1020 is faulty.

12

Keep this manual in a safe place for future reference.

K-1020

FRONT PANEL PARTS AND FUNCTIONS

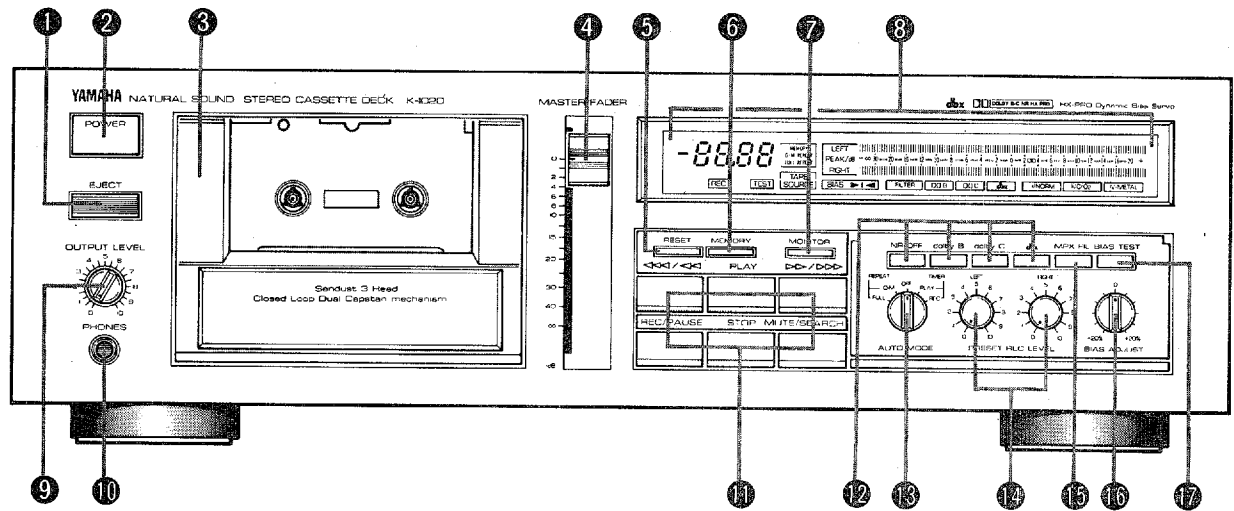

1 EJECT Button (EJECT)

When this button is pressed, the cassette holder opens. Use when loading and unloading cassette tapes.

2 POWER Switch (POWER)

This is push-on, push-off type power switch.

3 Cassette Holder

Holds the cassette tape.

4 MASTER FADER Control

This knob adjusts the range of the recording level set by the PRESET REC LEVEL CONTROLS. Normally it should be set to the "0" position.

* The MASTER FADER control will function only during the RECORD mode.

5 RESET Button

Push the RESET button to reset the counter reading to "0.00".

6 MEMORY Button

Push the MEMORY button when the counter is at the desired counter reading. Push the button again to release the memory function.

When the Memory position is set, the tape will automatically stop at that position during <<<</>>>> or >>>>/<<<< modes.

7 MONITOR Button

This button switches the MONITOR function between the source and the tape. This machine is equipped with an auto monitor function, but it can be changed to manual if so desired; for example, monitoring the just-recorded signal during tape recording.

8 MULTI FUNCTION DISPLAY

Please see page 4.

9 OUTPUT LEVEL Volume

Regulates level to the headphone jack, and line out to the amplifier.

10 Headphones Jack

When using headphones, insert the headphones plug into this jack.

11 OPERATION Buttons

PLAY: Press the button to start tape playback.

<<<</>>>> : The deck will REWIND(<<<</>>>>) or FAST FORWARD(>>>>/>>>>) the tape. Continuing to hold down either the <<<</>>>> or the >>>>/>>>> button will increase the REWIND or the FAST FORWARD speed, respectively. When these are pressed simultaneously with the MUTE/SEARCH button, it will be possible to search for the beginning of the present or the next selection.

REC/PAUSE: Pushing this button will activate the RECORDING STANDBY mode. Pushed during recording it will activate the REC/PAUSE mode.

STOP: Pushing this button will stop tape travel. Pushing this button during the RECORD mode will stop the recording.

MUTE/SEARCH: During Recording: When the MUTE/SEARCH button is pressed at any time during recording, a 4-second blank interval is automatically recorded on the tape. Then, the Rec Pause mode is engaged automatically. (Auto Rec Mute Operation)

In order to record a blank interval longer than 4 seconds, press the MUTE/SEARCH button and hold it in for the desired length of time. After the button is released, the 4 second blank interval will also be recorded automatically, after which the Rec Pause mode is engaged automatically. To create a blank interval on the tape during continuous recording, press the Play button during rec mute operation. During Playback: By pushing either the ◀◀◀/◀◀ or ▶▶▶ button simultaneously with this button, the tape will be advanced to the beginning of the song either before or after the one being listened to, from which point play will be resumed.

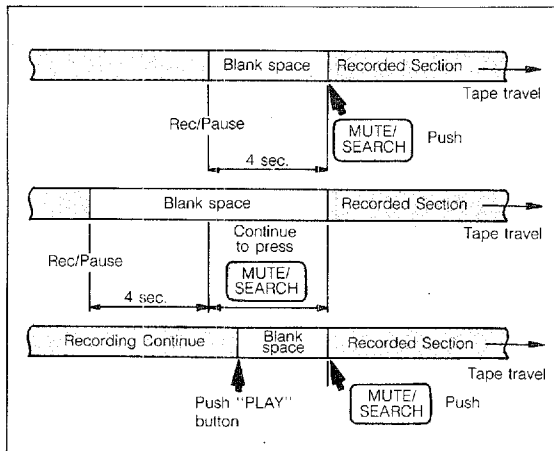

12 Noise Reduction Button (NOISE REDUCTION) NR OFF

For recording and playback without using the DOLBY NR or dbx systems, press this button. In the NR OFF position, signals do not pass through the noise reduction circuits and are output directly by the shortest route.

DOLBY B, C NR

Dolby noise reduction is an extremely effective method of reducing background hiss on tapes. The K-1020 incorporates both Dolby B NR and the newer Dolby C NR system. Dolby C NR is approximately twice as effective as Dolby B NR.

Tapes recorded with Dolby B NR should be played back with Dolby B NR on, and tapes recorded with Dolby C NR should be played back with Dolby C NR on.

* Dolby and the double D mark are trademarks of Dolby Laboratories Licensing Corp. Dolby noise reduction system manufactured under license from Dolby Laboratories Licensing Corp.

dbx NR

When recording with dbx NR, input signals with a large dynamic range are compressed to 1/2, and expanded by a factor of 2 to their original state when played back. This means that a large dynamic range can be obtained even from cassette tapes with small dynamic range recordings, and noise can also be reduced at the same time. If metal tapes are used for recording and playback, a dynamic range which would have been thought impossible with cassette tapes can be obtained. For recording and playback with the dbx system, press this button.

For playing back tapes which are not dbx recorded, set to the NR OFF position.

***"dbx" is a trademark of dbx Incorporated.

13 AUTO MODE Selector

This computer command function is for using the timer or locating the beginning of a selection with counter memory.

OFF

For normal playback or recording, set to this position.

REPEAT FULL

Either side of a tape (A or B according to the side loaded) is played 8 times from beginning to end.

REPEAT O-M

Playback is repeated 8 times between "0.00" on the counter and the counter number memorized with the memory button.

When no MEMORY position is set, the tape will stop at the "0.00" counter position during rewind.

TIMER PLAY

Can be used for timer playback, etc., with an external audio timer.

TIMER REC

Used for making timed, preset recordings with an external audio timer.

14 Preset Recording Level Controls

Adjusts the input level of the recording signal. Independent left/right controls also permit balance level setting.

15 MPX FILTER Switch

Press this switch when recording from an FM station while using the Dolby-NR system. The 19 kHz pilot signal may leak into the audio output, depending on the tuner and the broadcast condition. Since the 19 kHz pilot signal may cause improper operation of the Dolby NR system, this switch should be turned on when recording from an FM station, thus filtering out the 19 kHz pilot signal. This switch should be turned off when recording from other program sources.

16 BIAS Adjustment Control

This function is provided to adjust the recording bias to its optimum value according to the type of tape used.

Choose the optimum bias by watching the bias tuning display indicator.

- Refer to page 9, "Bias Adjustment".

17 TEST SWITCH

This switch will cause the ORBIT function to operate, and it is used during the adjustment of the bias. Normally this switch should be turned off.

K-1020

MULTI FUNCTION DISPLAY

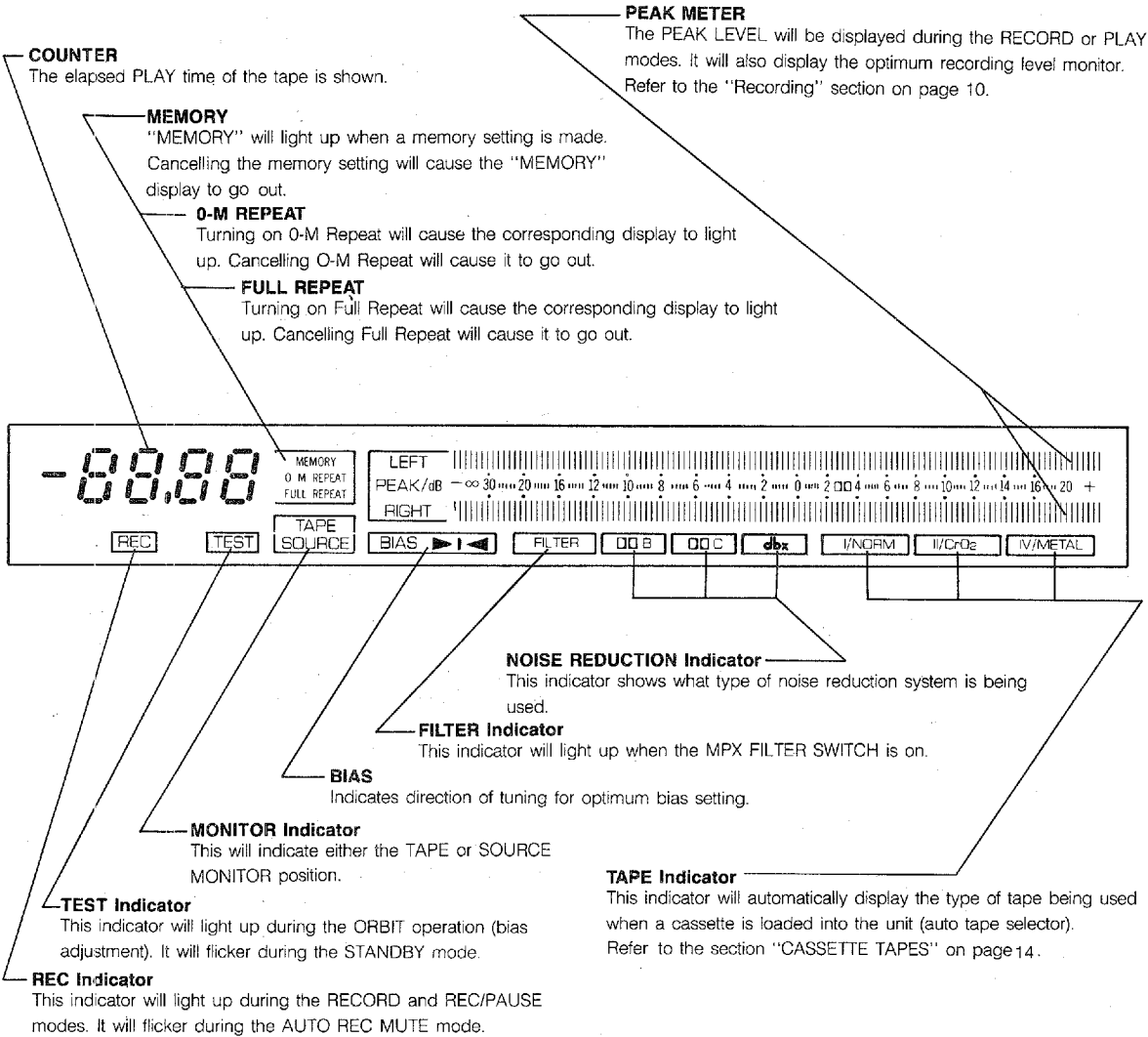

LINEAR COUNTER

•Precision of Counter

The tape counter is not a clock, and so there will be some errors in the time display compared to the actual recording time (this cannot be avoided, as a suitable method is adopted to provide a time display not only during recording and playback, but also during fast forward and rewind). The error depends on the type of tape being used.

The table below shows the range of error in the counter display compared to actual tape travel time, for Yamaha tapes run from beginning to end. It may be taken as a reference when using the counter.

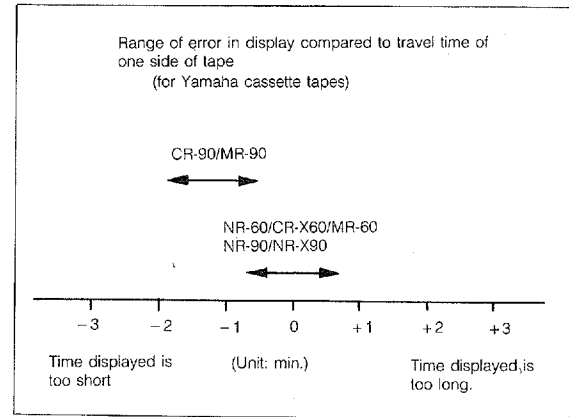

K-1020

CONNECTION DIAGRAM

Insert plugs firmly, taking care not to mix up L and R.

Be sure to connect the left (L) and right (R) channels consistently.

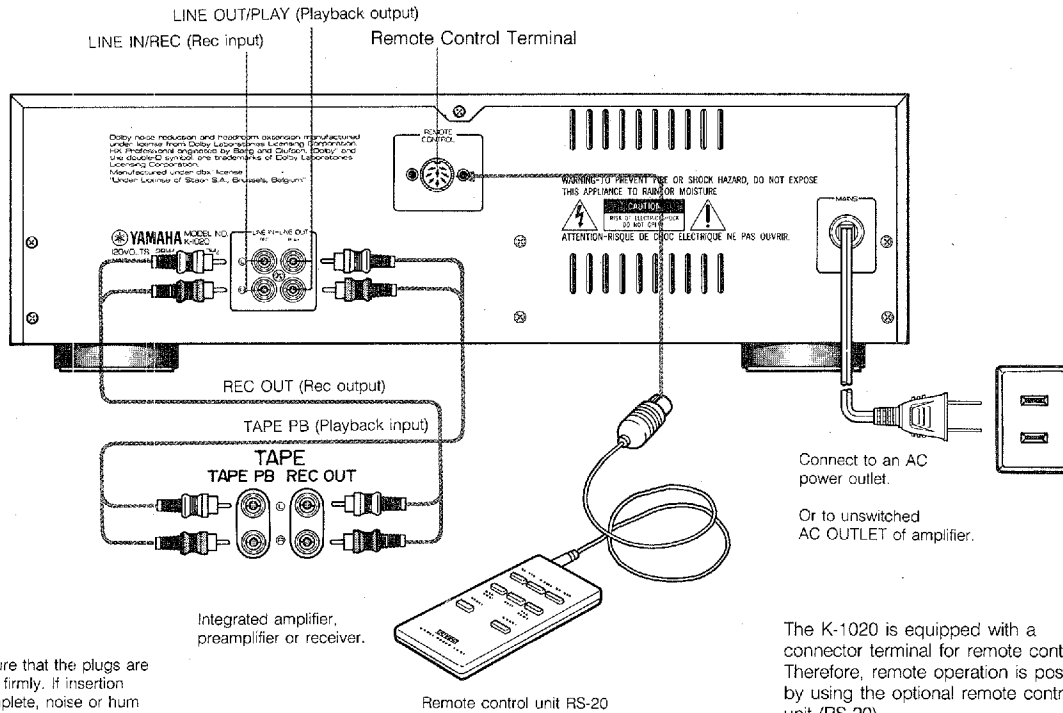

Make sure that the plugs are inserted firmly. If insertion is incomplete, noise or hum may result.

The K-1020 is equipped with a connector terminal for remote control. Therefore, remote operation is possible by using the optional remote control unit (RS-20).

Accessories

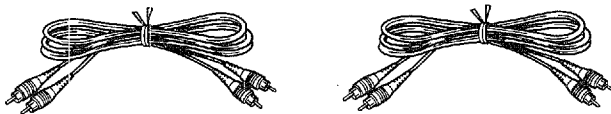

EIA rack mount adaptors are available for the K-1020, sold separately.

HOW TO LOAD AND UNLOAD CASSETTES

1. Open the cassette compartment cover by pressing the Eject button.
 2. The side of the tape you wish to record or playback should be facing the front. Insert the cassette with the exposed tape edge down, and fit it into the chamber.
 3. Push the cassette cover closed until you hear an audible click.
 4. To unload the cassette, press the Eject button.
- * Remember to keep the cassette compartment cover closed when not using the deck to protect the heads and inner assembly from exposure to dust and other foreign elements. The exposed edge of the tape should be facing down when inserted into the cassette compartment for either playback or recording.

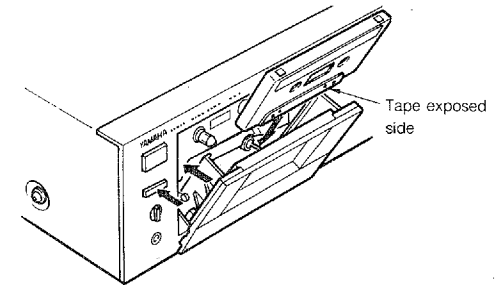

Automatic Tape Slack Tensioning Mechanism

When a tape is loaded while the power is on, tape slack tensioning operation will begin as soon as the tape is loaded. This is a special feature that insures that the dual capstan tape drive mechanism operates to its full potential. This automatic tensioning mechanism will also operate when the power is turned on after a tape has been loaded. However, if the tape has excessive slack, the tape slack tensioning mechanism may not be sufficient to take up all of the slack. Therefore, before loading a tape, be sure to take up as much of the tape slack as possible, by turning a pencil inside the cassette spool.

K-1020

THE HX PROFESSIONAL (DYNAMIC BIAS SERVO) SYSTEM

To improve the distortion characteristics during recording, it is important that, along with the recording tape head, a bias current precisely adjusted to the type of tape being used be supplied to the recording tape head. However, an excessively high bias current will cause the high frequency signal components to deteriorate, with a resultant rolling off of the high frequencies.

The HX-Professional system incorporates a DC-controlled bias servo amplifier between the recording tape head and the bias oscillator, which automatically controls the bias amount independently for the left and right channels, according to the level and the frequency components of the signal input. Thus, this system assures optimum recording of the entire audio frequency spectrum under all recording conditions. The deterioration of the high frequency signal components has been drastically improved, resulting in dynamic and clear recording with sufficient headroom, even at 0 dB. Unlike other noise reduction systems, the HX Professional system operates automatically, but only during recording. Thus, a tape recorded on a deck equipped with the HX Professional system can be played back on any conventional tape deck, and still retain the dynamic and clear sound that results from using the HX Professional system.

- Dolby noise reduction and headroom extension manufactured under license from Dolby Laboratories Licensing Corporation. HX professional originated by Bang and Olufsen.

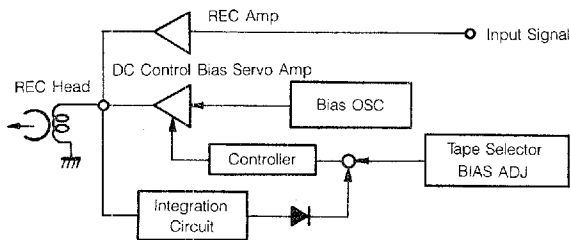

DOLBY NOISE REDUCTION

With cassette tapes, the most noticeable form of noise is high-frequency hiss. To reduce this hiss noise, the K-1020 has been equipped with a newly developed Dolby C noise reduction system in addition to its conventional Dolby B NR. Either type of noise reduction may be selected with the switch provided.

Dolby B NR has a noise-reduction effect of about 10 dB in the high-frequency range. The corresponding figure with Dolby C NR is about 20 dB, but this is over the entire range where the human ear is most sensitive to noise (2 kHz to 8 kHz). Dolby C NR also improves the tape's MOL (maximum output level).

Dolby C NR has two new circuits: a spectral skewing circuit and an anti-saturation network. By improving the saturation level of the tape it is possible to prevent high-frequency loss and encode/decode error, etc., improve dynamic range and signal-to-noise ratio, and make it easier to set the recording level. With Dolby C NR, it is possible to achieve the same noise reduction effect at both high and low

signal levels and to set the recording level at a point where side-effects such as "breathing" are eliminated. Also, by expanding the operating frequency range to two octaves more than that of Dolby B NR, overall noise balance is obtained and the system also becomes effective against high frequencies from the power supply. The graph shows the frequency response and the noise-reduction effect of recording and playback with Dolby B NR and Dolby C NR. The noise reduction effect of Dolby C NR is larger—approximately 20 dB.

Dolby noise reduction is a 2-part process that acts both on recording and playback; be sure that the Dolby NR switch is set to the same position on record and play.

- Noise in the source material can not be reduced with the Dolby NR system.

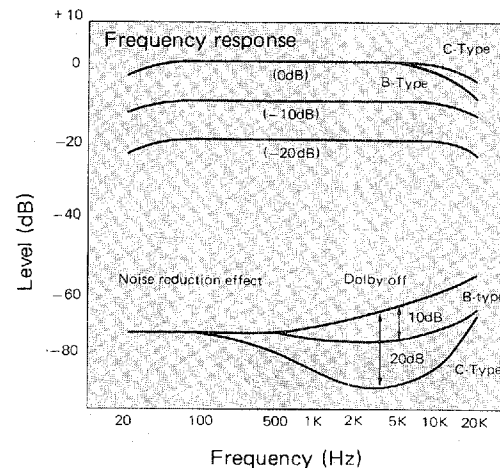

K-1020

3-HEAD CONFIGURATION AND AUTO MONITOR SYSTEM

dbx SYSTEM

The K-1020 incorporates a dbx system which greatly expands the dynamic range of cassette tapes. If the softest sound that the human ear can hear is "1", then the loudest is "1 million", or 120 dB. This is the dynamic range of the human ear. The dynamic range of cassette tape, however, is only about 55 dB. Even metal tapes only offer an improvement of 3 dB in the midrange and 8 dB in the high frequencies.

The dbx system works by compressing the dynamic range of the record signal by half and then doubling the dynamic range of the playback signal. (see diagram). With the dbx system functioning, a program source compressed to 50—60 dB at recording will be expanded to a dynamic range of 100—120 dB. At the same time, noise levels will be reduced throughout the entire frequency range, and the effective saturation level of the tape will be increased.

- Tapes not recorded with the dbx system should be played back with the dbx system off.

*The principle of dbx system

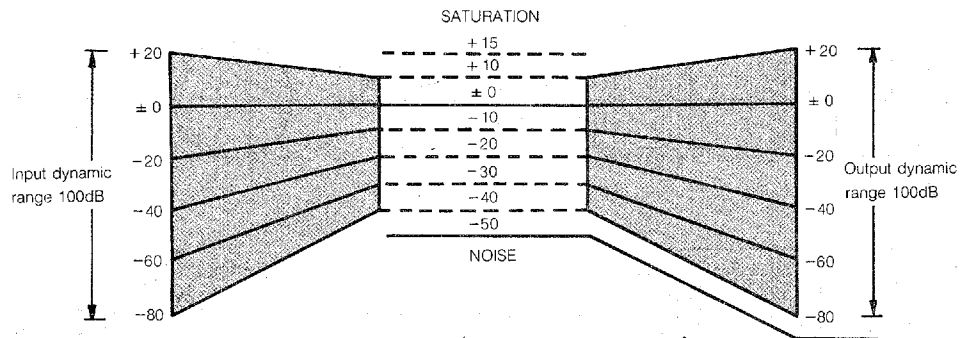
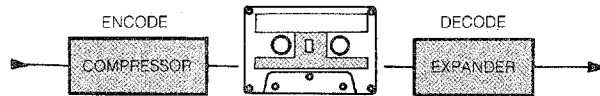

*Characteristics of dbx Encode/Decode

- ① ENCODE
- ② GENERAL
- ③ DECODE

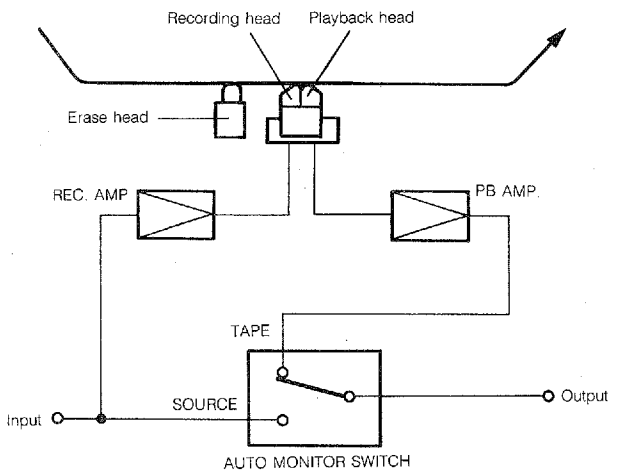
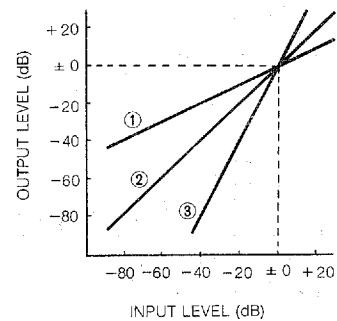

K-1020

BIAS ADJUSTMENT

The ORBIT system, with its microcomputer makes the trouble-some task of bias adjustment easier and clearer, so that tape performance can be fully exploited.

The optimum bias level can be set very easily; further adjustment is made to the bias level selected by the auto tape selector, watching the Bias tuning display and adjusting the Bias fine adjustment control.

- When the TEST button is ON, recording and playback cannot take place

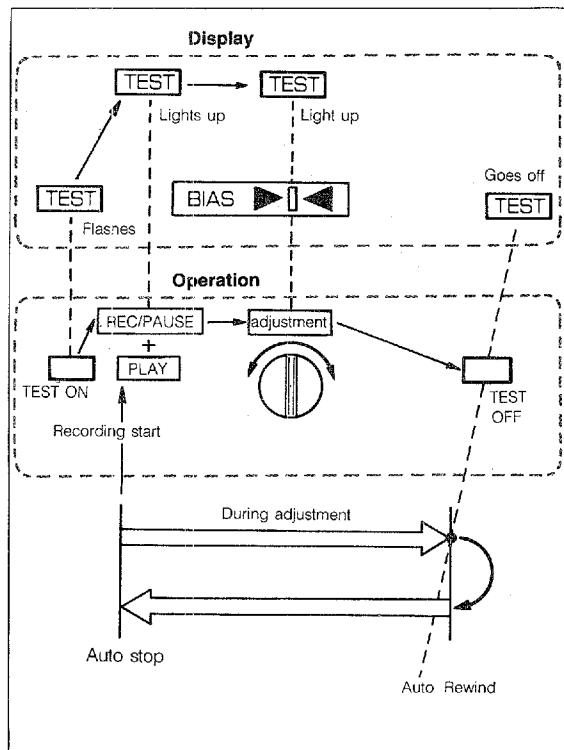

How to Adjust

- 1 Load cassette tape to be recorded.
 - 2 Press ORBIT TEST button to the ON position.
 - 3 Press the REC/PAUSE button and the PLAY button. The deck then enters the recording mode.
 - 4 Watching the tuning display, adjust the Bias control to give a flat frequency response.
- Refer to bias—frequency response curve.
The frequency response is flat when the tuning display is as shown.

- 5 After completing bias adjustment, switch ORBIT TEST button to OFF.

The tape is rewound at the same time. As the counter has memorized the point at which bias adjustment began, it returns to that point.

- 6 The bias is now set to its optimum value.

- if the heads are dirty or the tape is unsatisfactory, etc., it may not be possible to carry out bias adjustment.
- When the TEST button is ON, ordinary recording and playback cannot be carried out.

*Bias vs. Frequency Response

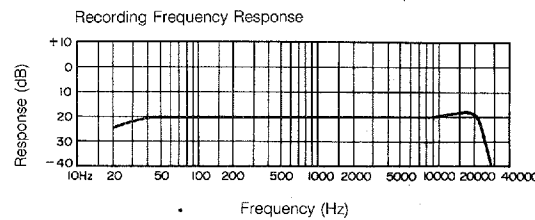

Tuning Display



Bias Control

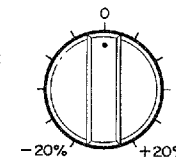

Optimum Bias
Flat frequency response
Sound quality normal

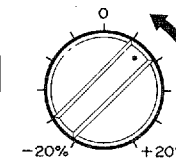
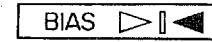
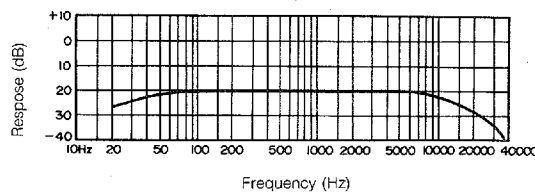

Excessive Bias (Over Bias)
High frequency response drop-off.

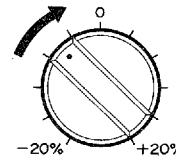
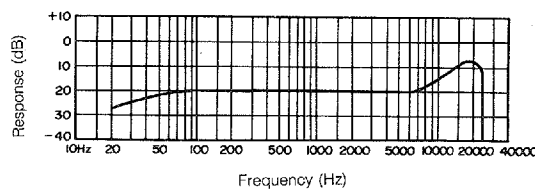

Insufficient Bias (Under Bias)
High frequency response rising.

K-1020

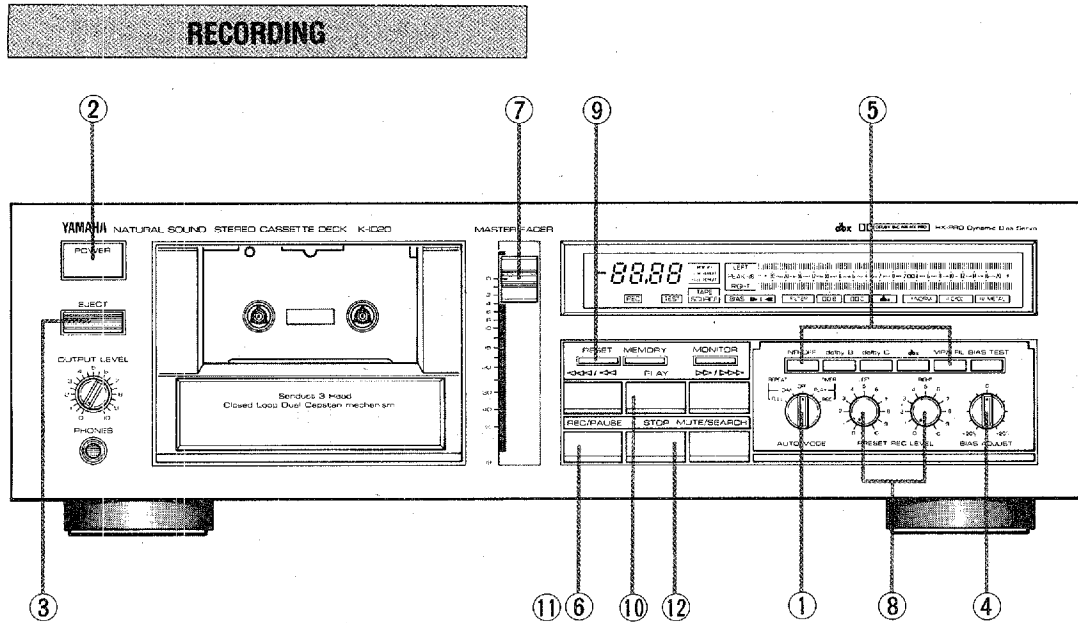

How to Record

Before recording

Refer to Connection Diagram. Check that leads and power cord are correctly wired.

- ① Set AUTO MODE selector to OFF.
- ② Set POWER switch to ON.
- ③ Press EJECT button, open the cassette holder and load a cassette tape.

When recording from the beginning of a tape, allow the tape to run short distance (about 10 seconds on the counter) until the leader tape has passed through.

- ④ Set the optimum bias for the tape according to "Bias Adjustment".
- ⑤ Set the recording mode. Switch on the MPX filter switch when recording FM stations while using Dolby NR.
- ⑥ Press REC/PAUSE button. The deck enters the recording standby mode.

- ⑦ Set the master fader knob to the "0" position.
- ⑧ Adjust the recording level to optimum point using level meters and Rec Level controls.
- ⑨ Press the RESET button to reset the counter. This is a reference for recording time and remaining tape time. It is also useful for locating recordings after they have been made.

Beginning recording

- ⑩ Press the PLAY button. The deck enters the recording mode.
- ⑪ If it is desired to interrupt recording temporarily, press the REC/PAUSE button. The deck enters the record standby mode. When it is desired to start recording again, press the PLAY button.
- ⑫ After the recording has been completed, press the STOP button.

- If the MUTE/SEARCH button is pressed during recording, an unrecorded passage can be put on the tape for as long as the button is pressed.

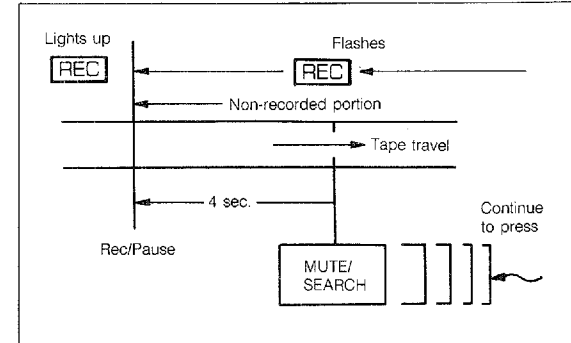

- When the tape has been wound completely, the auto shut off mechanism functions and the deck comes to a stop automatically.

REC Return Mechanism

- If the REWIND button is pushed during recording (playback), it stops automatically at the point where recording was last begun.
- REC Return mechanism works only after 4 seconds recording.
- If the tape counter is reset to the "0.00" position during recording, pressing the Rewind button for Rec Return will stop the tape at the "0.00" position, not at the point where recording began.

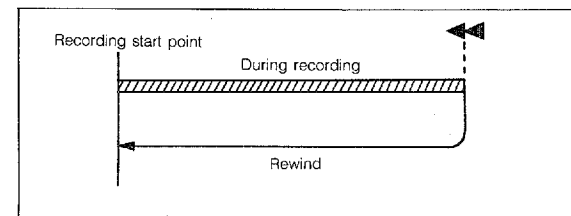

K-1020

SETTING THE RECORDING LEVEL

Setting the level recording is an important point for proper recording. The PEAK METER of this cassette tape deck is equipped with an optimum recording level monitor function, simplifying the process of setting the level. The optimum level indicator will automatically

change position according to the type of tape being used and the noise reduction system selected. Consequently, setting the optimum recording level is an accurate and simple operation, enabling the full dynamic range of the tape to be exploited.

- When using the NR OFF or DOLBY NR B, and C position, and normal or chrome tape.

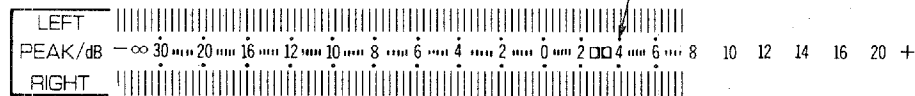

Set the REC LEVEL so that momentary signal peaks reach the +6 dB level.

- When using the NR OFF or DOLBY NR B, and C positions, and metal tape.



Set the REC LEVEL so that momentary signal peaks reach the +8 dB level.

- When using dbx, and normal, crone or metal tape.



Set the REC LEVEL so that momentary signal peaks reach the +16 dB level.

FADE-IN, FADE-OUT RECORDING

FADE IN will cause the recording level to gradually increase to the pre-set level, and FADE OUT will cause the recording level to gradually decrease from the pre-set level. Both functions can be controlled as desired. Using these functions to commence recording during a selection or for the gradual fading out of a selection will lend a distinctly professional touch to your recordings.

- **Fade-in recording**

Set the MASTER FADER knob to $-\infty$. After the recording starts, gradually raise the control setting to the 0 position.

- **Fade-out recording**

Gradually lower the MASTER FADER control setting to the $-\infty$ position, and then stop the recording.

Recording level set

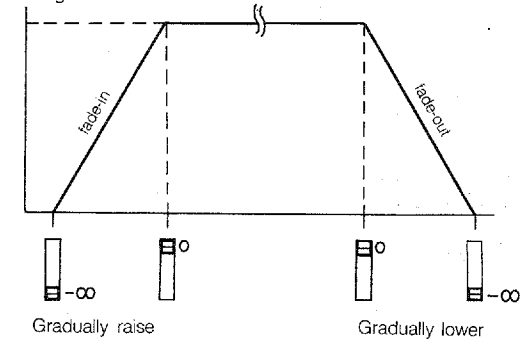

NOTE: The fade-in and fade-out features will not function during the PLAY mode. These functions will operate only during the RECORD mode.

K-1020

PLAYBACK

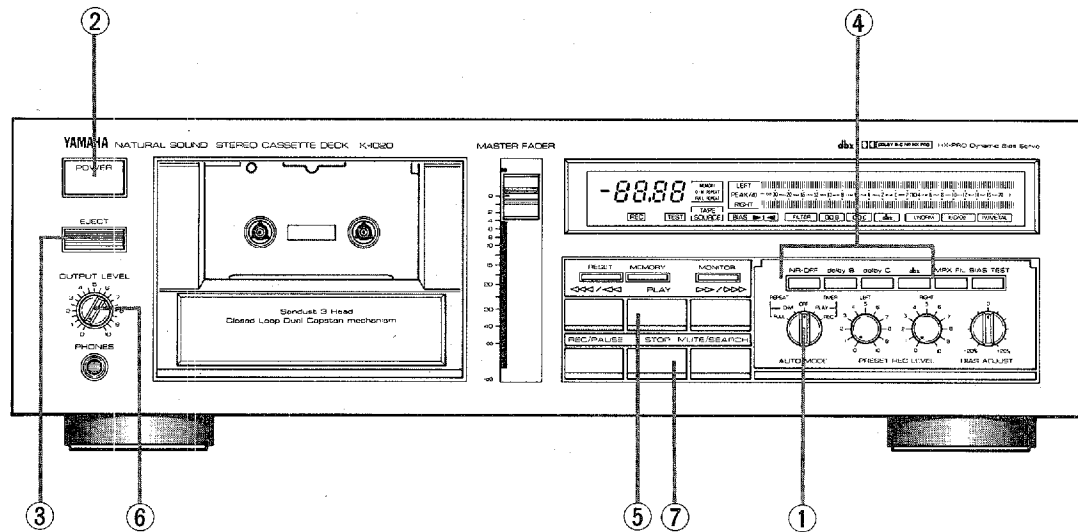

■ HOW TO PLAYBACK

• Before playback

Refer to connection diagram. Check that leads and power cords between units are correctly wired.

- ① Set AUTO MODE selector to OFF.
- ② Set POWER switch to ON.
- ③ Press EJECT button, open the cassette holder and load a pre-recorded cassette tape.
- ④ For a tape recorded with a noise reduction system, press either the Dolby B, Dolby B or dbx NR button according to the system used.

• Beginning playback

- ⑤ Press the PLAY button. The deck enters the playback mode.
- ⑥ Adjust the OUTPUT LEVEL control. Set the volume and tone controls on the amplifier to adjust sound quality as desired.
- ⑦ To stop playback, press the STOP button.

• Repeated playback of a selection

Using the AUTO MODE and MEMORY, the deck can play one or more selections repeatedly up to 8 times.

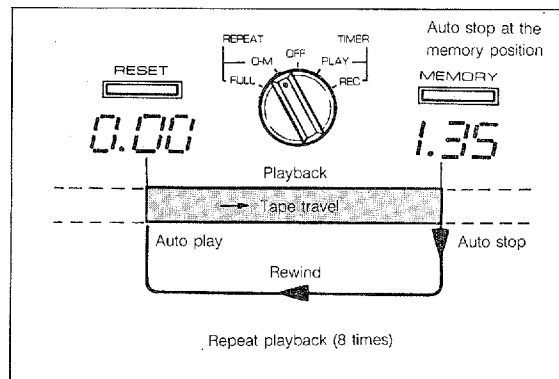

1. Load a pre-recorded tape, and begin playback.
2. Set AUTO MODE selector to REPEAT 0-M position.
3. Press RESET button at the beginning of the selection you want to play again, and set the counter to "0.00".
4. Press the MEMORY button at the end of the selection you want to play again. The MEMORY indicator lights up and the tape immediately begins rewinding.
5. The tape is rewound until the counter has returned to "0.00" (beginning of selection). The deck then enters the playback mode.
6. The tape plays back until it reaches the memorized counter number (end of selection). In this way, the same selection can be played again.
7. To erase the memory, press the MEMORY button once again. The Memory indicator goes out.

- When the memory position is at a - (minus) reading, commence playback from the memory position. The tape will automatically stop when "0.00" is reached, whereupon the tape will be rewound, and playback will be repeated between the above two points.

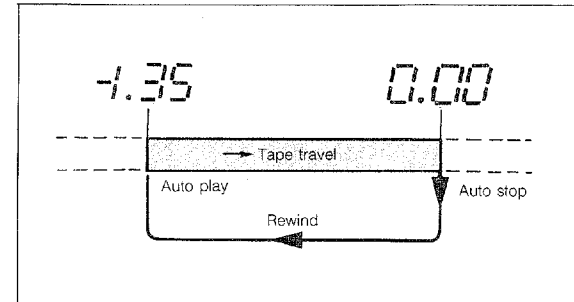

• Repeated playback of one side of a tape

1. Set the AUTO MODE switch to the REPEAT FULL position.
2. Load a tape, and the deck for playback. One side of a tape is played back up to 8 times.

K-1020

TIMER RECORDING AND TIMER PLAYBACK

Timer recording and timer playback is possible using an audio timer.

• Timer recording

- ① Connect the power cords between all units as shown in the wiring plan below.
- ② Switch on power to all units, and set the FUNCTION switch on the amplifier to TUNER. Choose a station. After selecting a station, it does not matter if the amplifier volume control is altered (it has no effect on recording level).
- ③ Adjust the deck as described in "Before Recording".
- ④ Set AUTO MODE selector to TIMER REC position.
- ⑤ Set timer to time desired.

* Allow some leeway between the timer setting and the time of the broadcast.

- ⑥ When the time reaches the setting, power is supplied to all units and recording begins.

• Timer playback

- ① Connect the power cords between all units as shown in the wiring plan below.
- ② Adjust the deck as described in "Before Playback".
- ③ Set the amplifier FUNCTION switch to TAPE.
- ④ Adjust volume with the amplifier volume control.
- ⑤ Set AUTO MODE selector to TIMER PLAY position.
- ⑥ Set timer to time desired.
- ⑦ When the time reaches the setting, power is supplied to all units and playback begins.

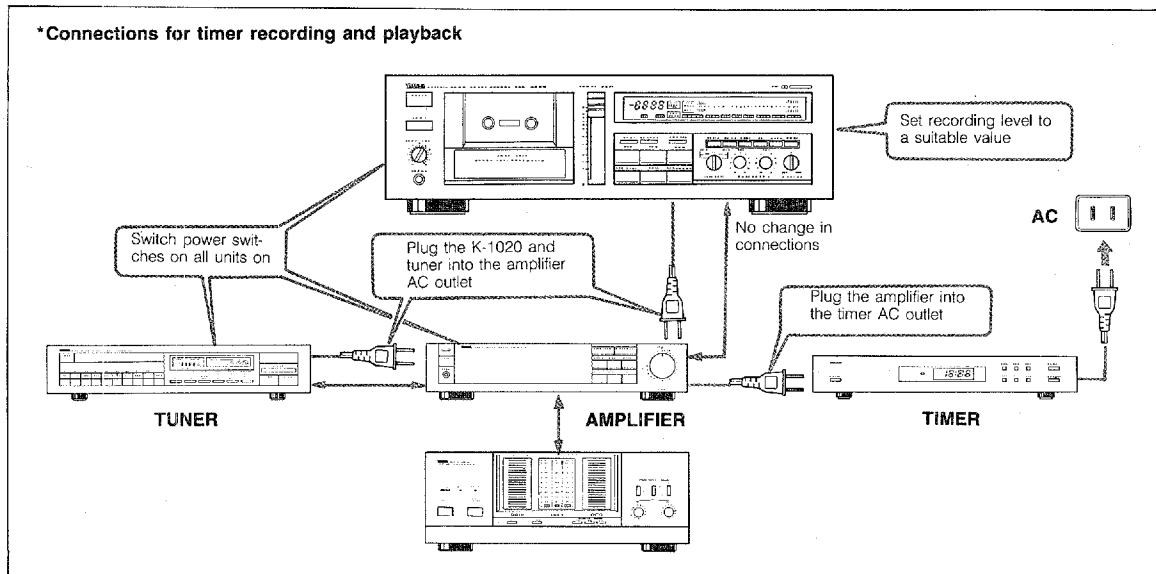

MAINTENANCE

After using your K-1020 for a certain length of time, it is possible that the sound of your tapes may deteriorate with fading, or noise as a noticeable result. This is caused by an accumulation of dirt or dust on the heads, capstan, or pinch roller, and magnetization of the heads. It is advisable to periodically clean and demagnetize the heads and to clean the capstan and pinch roller. Use a commonly available cotton swab and head cleaning solution to do this, or use a special head cleaning tape. Head demagnetizers are also commonly available.

- When cleaning the heads, be careful not to apply unnecessary pressure. When demagnetizing the heads, be sure to follow the instructions of the head demagnetizer carefully.
- For better access to the head assembly, the cassette compartment cover is detachable by pulling upward on it after it has been opened. To re-attach it, reverse the procedure.

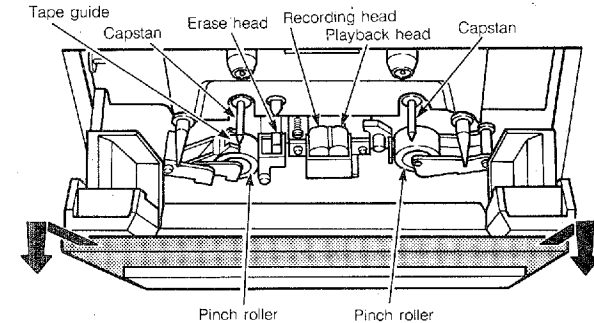

CASSETTE TAPES

• Classification of Cassette Tapes by Formulation

Cassette tapes are available in four basic types depending on their formulation, or type of magnetic material and manufacturing process. These four types are commonly known as Normal (LH), Chrome (CrO₂), Ferrichrome (FeCr), and Metal (Metal), and they each require specific bias, level, and equalization settings for optimum performance. Most cassette decks provide a tape type selector which gives you the proper bias, level, and equalization settings according to which type you have selected. The K-1020, however, does not have such a tape selector. Instead, it has an Auto Tape Selector which automatically adjusts for the proper bias, level and equalization according to the tape formulation—all you have to do is load a cassette and the Auto Tape Selector does the rest.

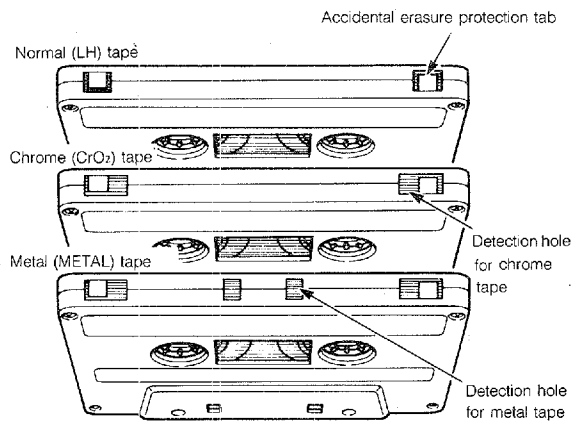

* Old-type Metal tape cassette shells do not have the necessary hole for Auto Tape Selector operation. It is recommended that you do not record with this kind of Metal cassette. However, metal tape cassettes recorded on another deck may be played back with the K-1020 at the Chrome (CrO₂) settings. All current cassette tapes will have this small opening in the cassette shell, so be sure you use suitable cassettes with the K-1020. Cassette shell structure of current tape types is shown above, illustrating this feature.

*The K-1020 does not have the required settings for Ferrichrome (FeCr) tape, since this tape formulation is not widely used. Should

you use a Ferrichrome tape, it will be recorded and played back at the Normal (LH) settings, and this will result in an unnatural high frequency emphasis. This effect may be compensated for somewhat by adjusting the tone controls of your amplifier.

• Protecting your recordings

All cassette tapes are provided with erasure protection holes to prevent recorded tapes from being accidentally erased. There is a small tab covering the hole on each cassette, and it should be broken off with a screwdriver after recording a tape. Without this tab covering the hole, it is impossible to record on that tape again; thus, you can keep any recorded tape for as long as you wish without fear of accidental erasure. Should you wish to use a cassette tape protected in this way for later recording, simply covering the hole with scotch tape will permit erasure and re-recording.

* When using Chrome (CrO₂), or Metal tape, make sure you do not cover the hole intended for the Chrome tape formulation check. (Refer to the illustration of cassette shells according to tape formulation for correct identification of each).

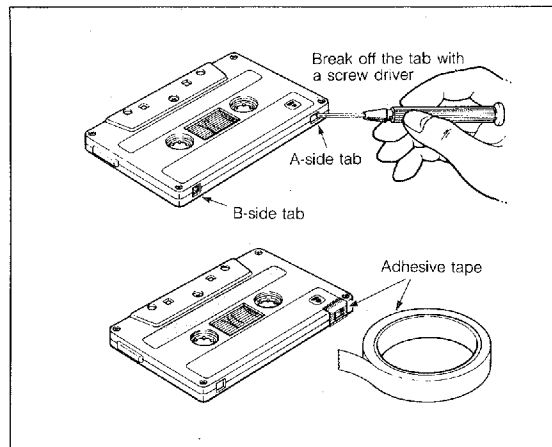

• Taking up slack in the tape

Slack in the tape inside of the cassette shell can be corrected by simply inserting a pencil into one of the spools and winding it until all the slack is taken up.

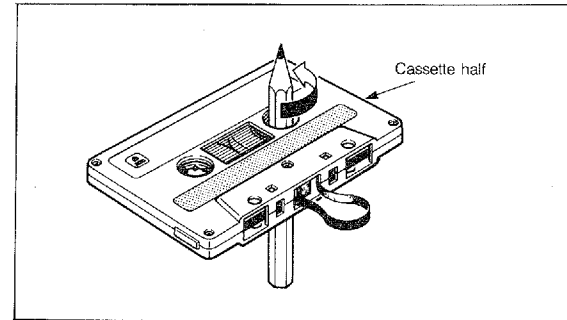

• Storage of your cassette tapes

After putting a cassette back into its case store in a location away from exposure to direct sunlight, humidity, high temperatures, and magnetic fields (away from television sets, speakers, etc.). High temperatures and humidity will damage the tape itself, while exposure to magnetic fields may cause a loss of recorded materials.

K-1020

TROUBLESHOOTING

When your cassette deck fails to function properly, before assuming it is faulty, check the following troubleshooting list. It details the corrective action you can take yourself without having to call a service engineer. If you have any doubts or questions, get in touch with your nearest Yamaha dealer.

Fault	Cause	Cure
Tape doesn't move in recording or playback.	<ul style="list-style-type: none"> • Power plug not properly plugged in. • End of tape. 	<ul style="list-style-type: none"> • Reinsert plug properly. • Rewind tape or flip it over.
Rec Standby button fails to function.	<ul style="list-style-type: none"> • No cassette tape loaded. • Protective tab broken off. 	<ul style="list-style-type: none"> • Load a cassette tape. • Change to different tape, or cover the hole remaining after removal of tab with cellophane tape.
Sounds become faint and sometimes inaudible.	<ul style="list-style-type: none"> • Head is dirty. • Head is magnetized. • Tape transport section dirty. 	<ul style="list-style-type: none"> • Clean head using cleaning tape. • Demagnetize head using head demagnetizer. • Change to different tape.
Recorded sound is warped.	<ul style="list-style-type: none"> • Tape is bad (stretched or deformed etc.) • Recording tape is itself warped. 	<ul style="list-style-type: none"> • Replace with a fresh tape. • As warping of tape itself cannot be rectified, replace with another tape and test.
Recorded sounds are distorted.	<ul style="list-style-type: none"> • Recording level is too high. 	<ul style="list-style-type: none"> • Check input level with meter and use lower rec level when recording.
Tape is playing back, but no sound is heard.	<ul style="list-style-type: none"> • Faulty connection between deck and stereo amplifier. 	<ul style="list-style-type: none"> • Rewire all connections from beginning.
Excessive noise.	<ul style="list-style-type: none"> • Head is dirty. • Head is magnetized. • Worn out or poor quality tape. • Connection(s) improperly made. • Affected by external electrical noise. 	<ul style="list-style-type: none"> • Clean head. • Demagnetize head with head demagnetizer. • Change to better tape. • Check input and output connections and reinsert properly. • Move away from electrical appliances (TV, fluorescent light, electric blanket, etc.)
Excessive wow (wavering of the sound).	<ul style="list-style-type: none"> • Dirty capstan, pinch roller, etc., or poor tape. • Tape is unevenly wound. 	<ul style="list-style-type: none"> • Clean capstan, pinch roller, or change to better tape. • Rewind tape.
Tape stops in the middle of recording or playback.	<ul style="list-style-type: none"> • Slack tape, or tape spillage wound around capstan. 	<ul style="list-style-type: none"> • Insert pencil in hole in cassette shell and turn to take up slack.
Fails to record.	<ul style="list-style-type: none"> • Rec Level control too low. • Protective tabs broken off. 	<ul style="list-style-type: none"> • Adjust rec level control. • Change tape or cover protective hole with cellophane tape.
Mute Search does not operate.	<ul style="list-style-type: none"> • Recorded section is too short. • Recorded section has low-level portions. • Conversation, etc. has been recorded. 	<ul style="list-style-type: none"> • Blank sections must be at least 4 seconds long.

K-1020

Fault	Cause	Cure
High frequencies in the playback sound are emphasized and unpleasant to listen to, and noise level (hiss) is also high.	<ul style="list-style-type: none"> • dbx or Dolby-recorded tape is played back in NR OFF position. 	<ul style="list-style-type: none"> • Play back in appropriate DOLBY or dbx position.
Playback sound is muffled and high frequencies are inaudible.	<ul style="list-style-type: none"> • Normally-recorded tape is played back in DOLBY or dbx. • Heads are dirty. • Heads are magnetized. 	<ul style="list-style-type: none"> • Play back in NR OFF position. • Clean heads and carry out demagnetization with head demagnetizer.
Playback sound balance is poor and sound seems muffled. Sound seems faint.	<ul style="list-style-type: none"> • dbx-recorded tape is played back in DOLBY B, C or NR OFF position. 	<ul style="list-style-type: none"> • Play back in dbx position.
Playback sound balance is poor. Sounds are sometimes too loud, sometimes too soft, and meter deflection is abnormally high.	<ul style="list-style-type: none"> • Normal or DOLBY-recorded tape is played back through dbx. 	<ul style="list-style-type: none"> • Play back in the position in which it was recorded.
When playing back tapes recorded on other decks, meter deflections are greater (smaller) than when recording.	<ul style="list-style-type: none"> • Basic levels are different for different cassette decks. 	<ul style="list-style-type: none"> • This is not a fault.
Does not operate when record standby button is pressed.	<ul style="list-style-type: none"> • No cassette tape has been loaded. • Protective accidental erasure tabs on cassette have been broken off. 	<ul style="list-style-type: none"> • Load a cassette tape. • Replace cassette tape, or cover tab holes with tape.
Recordings cannot be made.	<ul style="list-style-type: none"> • Recording level controls (PRESET REC LEVEL) are set too low. • MASTER FADER control is set too low. 	<ul style="list-style-type: none"> • Adjust level with the level control. • Set to "0" position.
Recordings cannot be made with TIMER REC (deck only plays back).	<ul style="list-style-type: none"> • Protective accidental erasure tabs on cassette have been broken off. 	<ul style="list-style-type: none"> • Replace cassette tape, or cover tab holes with tape.

K-1020

BLOCK DIAGRAM

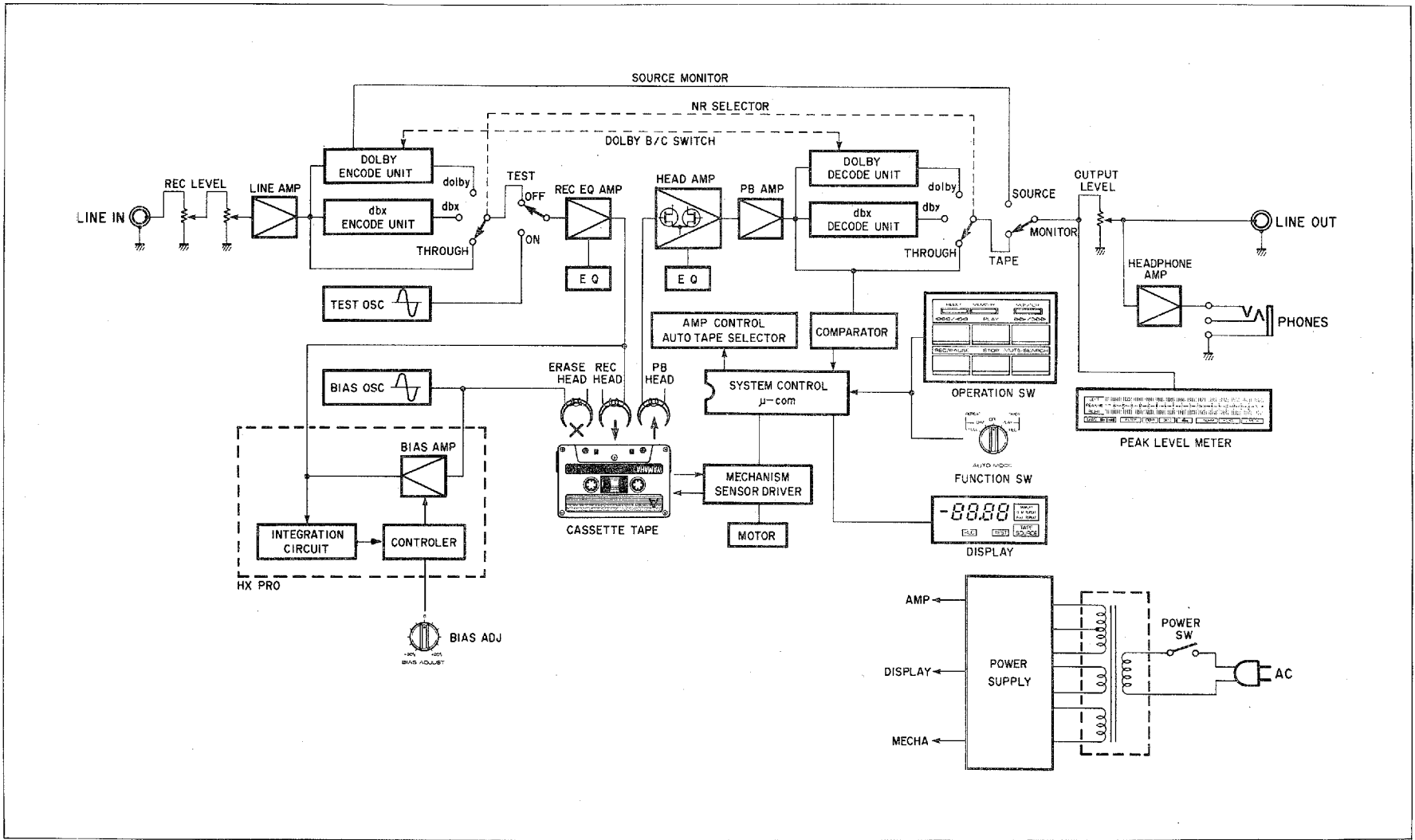

SPECIFICATIONS

Type	4-track, 2-channel stereo
Heads	R & P Heads: Combination, Pure Sendust with triple-laminated core Erase head: Ion-plating Ferrite, Double-gap
Motors	Capstan: DC Servo Motor Reel: Flat torque DC motor Assist: DC motor
Wow & Flutter	No more than $\pm 0.06\%$ (W.Peak); No more than 0.03% (W.RMS)
Fast Wind Time	About 70 seconds /45 seconds (High Speed winding) (C-60)
Frequency Response	
Normal tape (-20 dB)	20 to 18,000 Hz ± 3 dB
Chrome tape (-20 dB)	20 to 20,000 Hz ± 3 dB
Metal tape (-20 dB)	20 to 23,000 Hz ± 3 dB
Signal to Noise Ratio	
Dolby off	More than 59 dB
Dolby B on	More than 67 dB
Dolby C on	More than 75 dB
dbx on	More than 95 dB
Harmonic Distortion	
Normal tape	Less than 0.5%
Chrome tape	Less than 0.5%
Metal tape	Less than 0.8%
Input Sensitivity/Impedance	
Line	40 mV/30 k-ohms
Output Level/ Load Impedance	
Line	360 mV/47 k-ohms
Headphones	3.6 mW/8 ohms
Channel Separation (3150 Hz)	40 dB
Cross Talk (125 Hz)	60 dB
Power Supply	AC 120V, 60 Hz
Power Consumption	28 watts
Dimensions (W x H x D)	435 x 134 x 380 mm (17-1/8" x 5-1/4" x 15")
Weight	7.6 kg (16 lbs. 12 oz.)

* Specifications subject to change without notice.

SINCE 1887  **YAMAHA**
NIPPON GAKKI CO., LTD. HAMAMATSU, JAPAN